

Series RO80 薄膜外殼(低壓型) RO80 Membrane Housing Type(Low Pressure) RO80 膜用ハウジング(低圧対応)

設計壓力 Design P. 20kg/cm² 操作壓力 Operating P. 14kg/cm²
設計圧力 操作圧力

設計溫度 Design T. 70°C 操作溫度 Operating T. 40°C
設計温度 操作温度

標準口径 Standard Nozzle 標準口径
N1-1内牙 N2-1 1/2" 機械接頭
N1-1"PT-F N2-1 1/2" V
N1-1"PT-F N2-1 1/2" V



RO80 40 4 25 PF 40 V E 15

產品代碼 Product code 商品コード	管身長度 (英吋) Length of Shell (inch) シェル寸法 (インチ) 40 80 120 160 200	材質 Material 材質 4 - 304 6 - 316	N1 規格 N1 Size N1 寸法 25 - 1" 40 - 1-1/2" 50 - 2"	N1 類型 N1 Type N1 規格 PF - BSPT-F BF - BSPF-F NF - NPT-F V - 機械接頭 J - Clamp	N2 規格 N2 Size N2 寸法 25 - 1" 40 - 1-1/2" 50 - 2"	N2 類型 N2 Type N2 規格 PF - BSPT-F BF - BSPF-F NF - NPT-F V - 機械接頭 J - Clamp	O型環材質 O-ring Material Oリング材質 E - EPDM	内面表面處理 Interior surface finished 内面仕上げ 1 - 酸洗 / 酸洗淨 ACID - Washing 外面表面處理 Exterior surface A finished 外面仕上げ 5 - 拋砂 / ヘアライン仕上げ Burnishing
--------------------------------------	---	---	---	---	---	---	---	--

RO80 Membrane Housing Type(Low Pressure)

No.	名稱	Description	No.	名稱	Description	No.	名稱	Description
1	束環	Clamp	4	O型環	O-ring	7	機械接頭	Victaulic coupling
2	RO端板	RO head	5	PVC接管	PVC coupling	8	管殼	Shell
3	O型環	O-ring	6	桶唇	Shell flange			

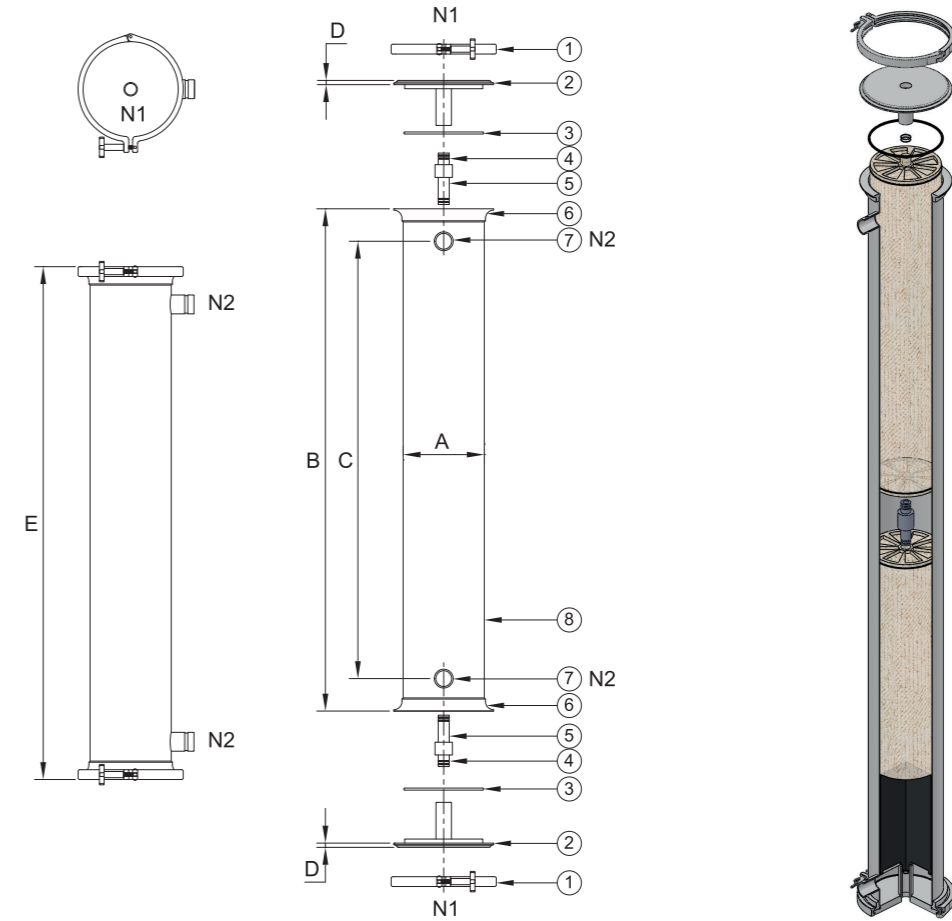

型式 Model	A m/m	B m/m	C m/m	D m/m	E m/m	N1	N2	重量 Weight
RO8040	Ø210	1300	1132	11	1328	1"	1 1/2"	31kg
RO8080	Ø210	2316	2148	11	2344	1"	1 1/2"	47kg
RO80120	Ø210	3332	3164	11	3360	1"	1 1/2"	63kg
RO80160	Ø210	4348	4180	11	4376	1"	1 1/2"	78kg
RO80200	Ø210	5364	5196	11	5392	1"	1 1/2"	94kg